

RW-B, RW-T and RW-V Series

50RW-B
Net wt. 232 lbs.
5.0" C.D.

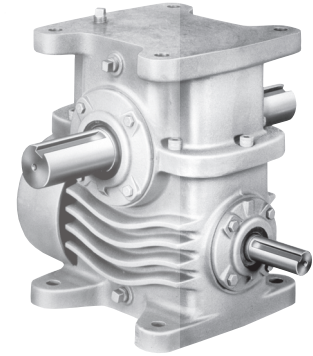

50RW-T
Net wt. 232 lbs.
5.0" C.D.

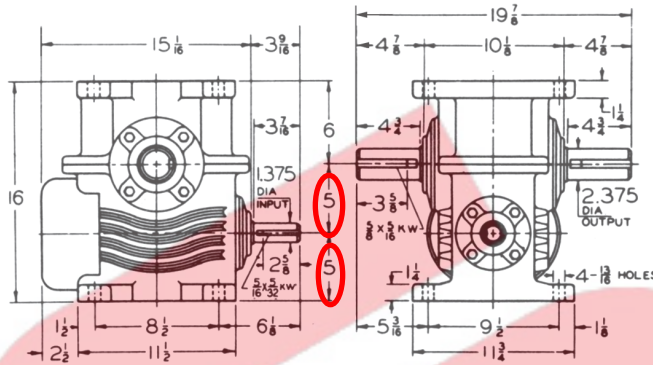
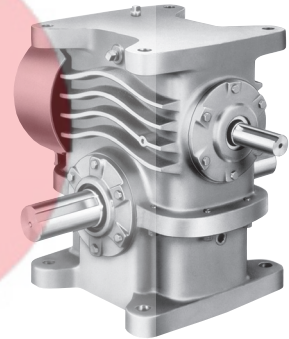
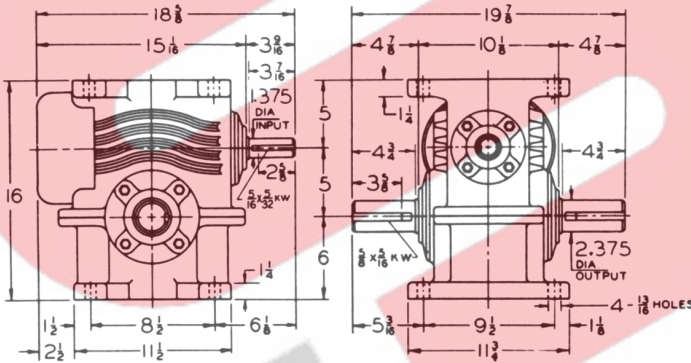

50RW-V
Net wt. 232 lbs.
5.0" C.D.

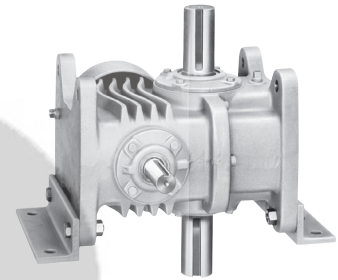
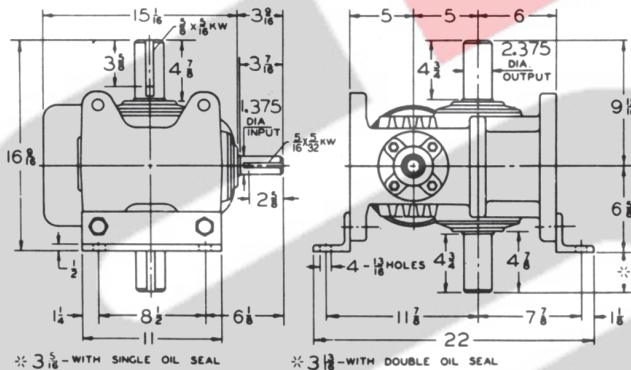

Angle brackets are not included with the reducer.

1.00 Service Factor* - Single Reduction Wormgear - 50RW Powergear Universal Model

TORQUE and HORSEPOWER RATINGS																		
RATIO	AT 1750 RPM INPUT			AT 1150 RPM INPUT			AT 870 RPM INPUT			AT 580 RPM INPUT			AT 300 RPM INPUT			AT 100 RPM INPUT		
	Input HP	Output		Input HP	Output		Input HP	Output		Input HP	Output		Input HP	Output		Input HP	Output	
	R.P.M.	▲Torque		R.P.M.	▲Torque		R.P.M.	▲Torque		R.P.M.	▲Torque		R.P.M.	▲Torque		R.P.M.	▲Torque	
5	25.25	350.0	4300	20.79	230.0	5344	18.60	174.0	6274	15.47	116.0	7743	10.11	60.0	9570	4.02	20.0	11029
10	16.64	175.0	5542	13.84	115.0	6917	12.47	87.0	8155	10.13	58.0	9790	6.45	30.0	11670	2.53	10.0	13139
15	12.31	116.6	5991	10.34	76.6	7512	9.30	58.0	8813	7.56	38.7	10511	4.83	20.0	12448	1.91	6.6	13958
20	9.61	87.5	6113	8.18	57.5	7737	7.29	43.5	8964	5.87	29.0	10547	3.71	15.0	12286	1.47	5.0	13610
25	7.94	70.0	6162	6.80	46.0	7823	6.06	34.8	9040	4.88	23.2	10592	3.09	12.0	12273	1.23	4.0	13558
30	6.92	58.4	6224	5.92	38.4	7836	5.36	29.0	9154	4.41	19.3	10877	2.88	10.0	12810	1.18	3.3	14338
40	5.31	43.7	6125	4.60	28.7	7771	4.14	21.8	8781	3.38	14.5	10531	2.20	7.5	12222	.90	2.5	13507
50	4.27	35.0	5899	3.73	23.0	7498	3.36	17.4	8644	2.76	11.6	10111	1.81	6.0	11686	.75	2.0	12904
60	3.48	29.2	5577	3.06	19.2	7094	2.76	14.5	8140	2.26	9.7	9470	1.48	5.0	10854	.62	1.6	11974

Inch-pounds

Overhung load (O.H.L.) for 50RW-B, RW-T is 4477 pounds, for 50RW-V is 4040 pounds one shaft diameter from housing.

* Refer to page 275 for other service factors. Refer to page 284 for shaft arrangements.