

# motor change HRD 7 BOOSTED from ATB Wolong to VEM



## technical modification

Change of the motor high pressure fan **HRD 7 BOOSTED**  
from ATB Wolong to VEM

## time line

Change of the series as of 1st quarter 2023  
**HRD 7B BOOSTED**

## motivation for change

- extended options (see next page)
- higher technical standard
- high supply security through strategic partnership with VEM

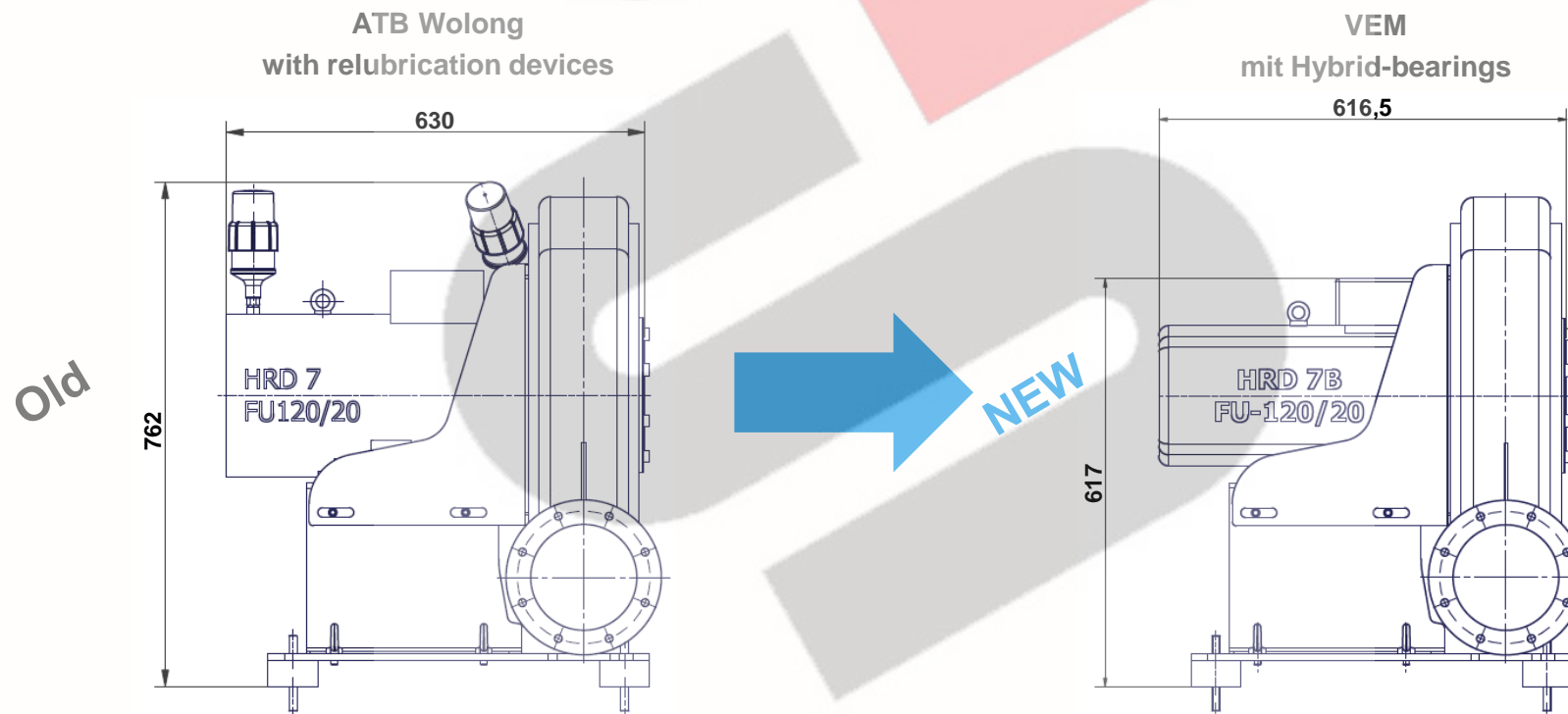

# motor change HRD 7 BOOSTED

## from ATB Wolong to VEM



### VEM Motor with Hybrid-bearings

#### That's changing:

- no relubrication devices
- no more activation of the relubrication units during commissioning
- hybrid bearings = emergency running performance / insulating bearings
- shorter motor and lower installation height above motor
- identical connection dimensions
- now motor mounted frequency converter (FUK) possible
- high supply security through strategic partnership with VEM
- minor reduction in bearing life from 14000 h to 12500 h
- connection direction in terminal box D = rear
- no 1:1 motor exchange possible (ATB = special motor base dimension)
  
- new material numbers and new device names HRD 7B FU-120/15 and HRD 7B FU-120/20 for clear traceability of the conversion

